

HS-S045 HEPA Wall Filter



Description

For stabile placement at a wall the unit consists of a durable frame, which is made of gas-tightly welded aluminum sections. The outer angle sections form a surrounding mounting frame with a broad contact surface for easy and tight installation onto the wall.

This wall filter also features aluminum supporting angles as well as a spindle-type tightening device made out of chromium-plated parts, which guarantee exact fit and leak-proofness between filter cells and the frames' contact area. The filter will be delivered ready-to-use.

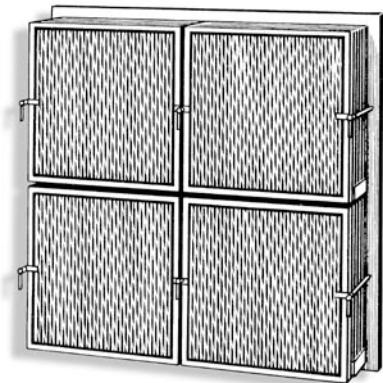

for filter cells **610x610x292 mm**
610x610x150 mm
610x610x 78 mm

Height [mm]	Dimensions	Width [mm] on top of each other	filter cells - next to each other					
			707	1334	1961	2588	3215	3842
707	number of filters: weight [kg]:	1	1 5	2 8	3 11	4 14	5 16	6 19
1334	number of filters: weight [kg]:	2	2 8	4 13	6 18	8 23	10 28	12 33
1961	number of filters: weight [kg]:	3	3 11	6 18	9 25	12 32	15 39	18 46
2588	number of filters: weight [kg]:	4	4 11	8 23	12 32	16 41	20 50	24 65
3215	number of filters: weight [kg]:	5	5 16	10 28	15 40	20 50		
3842	number of filters: weight [kg]:	6	6 20	12 33	18 46	24 65		

for filter cells **762x610x292 mm**

Height [mm]	Dimensions	Width [mm] on top of each other	filter cells - next to each other					
			859	1638	2417	3196	3975	4754
707	number of filters: weight [kg]:	1	1 5	2 9	3 12	4 16	5 19	6 23
1334	number of filters: weight [kg]:	2	2 8	4 14	6 20	8 26	10 32	12 37
1961	number of filters: Gewicht [kg]:	3	3 12	6 20	9 28	12 36	15 44	18 53
2588	number of filters: weight [kg]:	4	4 15	8 25	12 36			
3215	number of filters: weight [kg]:	5	5 18	10 31	15 44			
3842	number of filters: weight [kg]:	6	6 21	12 36	18 52			

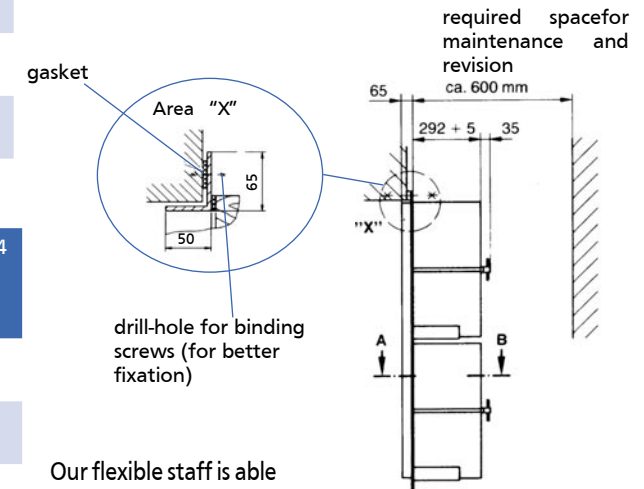
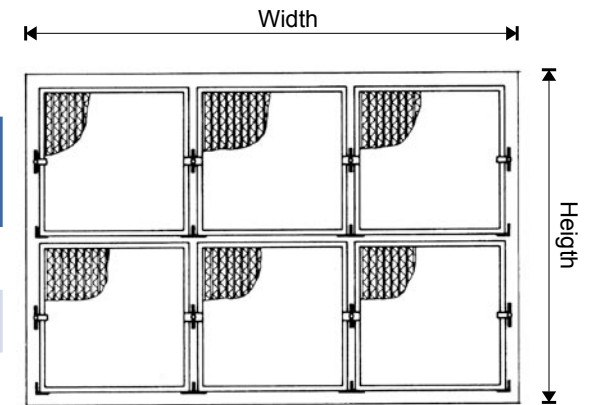

Our flexible staff is able to meet every customers' needs. Please ask for further dimensions and configurations.

